

# GGB-1916

**GNSS/2.5G GSM/GPRS/Bluetooth Module**

Datasheet



**Document history**

Version	Date	Updates
0.1	May 25, 2016	<ul style="list-style-type: none"><li>• Creation.</li></ul>
0.2	August 26, 2016	<ul style="list-style-type: none"><li>• Correct pin assignment.</li><li>• Add the information for internal verification test.</li></ul>
0.3	November 17, 2016	<ul style="list-style-type: none"><li>• Revised Bluetooth output power to Maximum 4dBm <math>\pm</math> 3dBm.</li><li>• Revised GSM Sensitivity to <math>\leq</math> -107dBm @ 1900MHz.</li><li>• Revised the values of the current consumption.</li><li>• Add the current consumption of GGB-1916-A.</li></ul>
1.0	November 24, 2016	<ul style="list-style-type: none"><li>• Revised AT command of sleep mode.</li></ul>
1.1	November 29, 2016	<ul style="list-style-type: none"><li>• Revised the dimension of the box.</li></ul>
1.2	April 7, 2017	<ul style="list-style-type: none"><li>• Added the weight information.</li><li>• Revised the dimension of the box.</li></ul>

## Contents

<b>1. INTRODUCTION .....</b>	<b>5</b>
1.1 PRODUCT FEATURES .....	5
1.2 BLOCK DIAGRAM .....	6
<b>2. PIN DEFINITION .....</b>	<b>7</b>
2.1 PIN ASSIGNMENT.....	7
2.2 PIN DESCRIPTION.....	7
<b>3. ELECTRICAL SPECIFICATIONS.....</b>	<b>10</b>
3.1 ABSOLUTE MAXIMUM RATING .....	10
3.2 ELECTRICAL CHARACTERISTICS .....	10
3.3 TEMPERATURE CHARACTERISTICS .....	13
<b>4. MECHANICAL SPECIFICATION.....</b>	<b>13</b>
4.1 OUTLINE DIMENSIONS .....	13
4.2 RECOMMENDED LAYOUT PATTERN.....	14
<b>5. PRODUCT HANDLING.....</b>	<b>15</b>
5.1 ESD PRECAUTION .....	15
5.2 PACKAGING .....	15
5.2.1 <i>Tape and reel packaging</i> .....	15
5.2.2 <i>Box packaging</i> .....	16
5.3 MOISTURE SENSITIVITY LEVEL.....	17
5.4 REFLOW SOLDERING.....	17
<b>6. PRODUCT MARKING AND ORDERING INFORMATION .....</b>	<b>18</b>
6.1. PRODUCT MARKING.....	18
6.2. ORDERING INFORMATION .....	18

**Table index**

**TABLE 1: MODULE KEY FEATURES** ..... 5

**TABLE 2: PIN DESCRIPTION** ..... 7

**TABLE 3: ABSOLUTE MAXIMUM RATING**..... 10

**TABLE 4: ELECTRICAL CHARACTERISTICS** ..... 10

**TABLE 5: CURRENT CONSUMPTION OF GGB-1916-A** ..... 11

**TABLE 6: CURRENT CONSUMPTION OF GGB-1916-B** ..... 12

**TABLE 7: TEMPERATURE CHARACTERISTICS**..... 13

**TABLE 8: ORDERING INFORMATION** ..... 18

## Figure index

FIGURE 1: MODULE BLOCK DIAGRAM.....	6
FIGURE 2: PIN ASSIGNMENT.....	7
FIGURE 3: OUTLINE DIMENSIONS.....	13
FIGURE 4: RECOMMENDED LAND PATTERN DIMENSIONS.....	14
FIGURE 5: RECOMMENDED STENCIL DESIGN.....	14
FIGURE 6: TAPE DIMENSIONS (MM).....	15
FIGURE 7: REEL DIMENSIONS (MM).....	16
FIGURE 8: BOX PACKAGING.....	16
FIGURE 9: RECOMMENDED REFLOW PROFILE.....	17
FIGURE 10: LABEL OF GGB-1916 MODULE.....	18

## 1. Introduction

GGB-1916 module is a versatile module that integrates GNSS, 2.5G GSM/GPRS and classic Bluetooth in a miniature QFN (Quad Flat No leads) form factor. Its built-in highly integrated power management units and efficient DC/DC converters make not only switch individual features of the power by software commands but also perform brilliant low power consumption. All parts of RF functions are included, such as the transceiver and power amplifier of GSM, band pass filter of Bluetooth as well as SAW filter and LNA of GNSS. No abstruse RF knowledge is required. Just connect antennas to it. Besides, all functions of GNSS, A-GNSS, GSM and Bluetooth are software controlled via single UART port. These ease the use, shorten the development time and make the fast time to market.

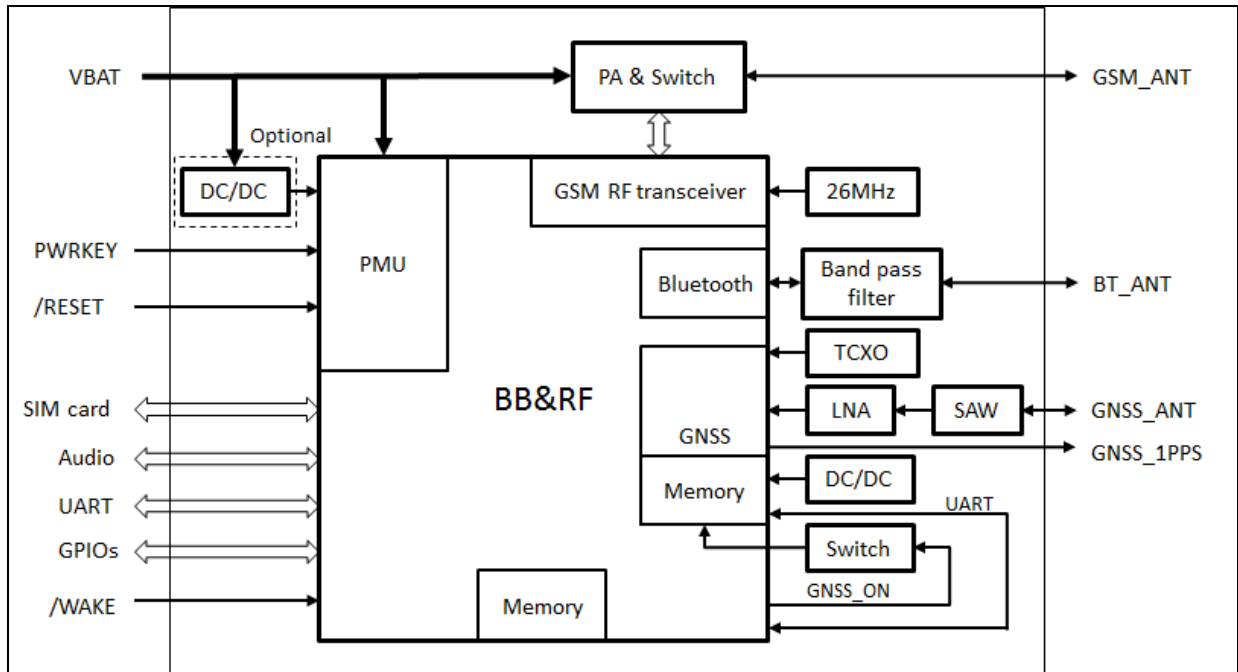
### 1.1 Product features

**Table 1: Module key features**

GNSS feature	Description	
GPS, GALILEO, QZSS	L1 1575.42MHz, C/A code.	
GLONASS	L1 1598.0625MHz ~ 1605.375MHz, C/A code.	Switchable between GLONASS and BEIDOU.
BEIDOU	B1 1561.098MHz, C code.	
SBAS	WAAS, EGNOS, MSAS, SDCM, GAGAN	
A-GNSS	<ul style="list-style-type: none"> <li>● EPO (Extended Prediction Orbit) data service</li> <li>● EASY: Embedded Assist System which accelerates TTFF by predicting satellite navigation messages from received ephemeris.</li> </ul>	
Channels	Support 99 channels (33 tracking, 99 acquisition)	
Update rate	1 Hz default, up to 10 Hz	
Sensitivity	<ul style="list-style-type: none"> <li>● Tracking: up to -165 dBm</li> <li>● Acquisition: up to -148 dBm</li> </ul>	
Antenna	Passive or active antenna support	
GSM/GPRS feature	Description	
Frequency bands	Quad-band GSM 850/E-GSM 900/DSC 1800/PCS 1900	
Output power	<ul style="list-style-type: none"> <li>● Class 4 (2 W) for GSM 850 and E-GSM 900</li> <li>● Class 1 (1 W) for DCS 1800 and PCS 1900</li> </ul>	
GSM Sensitivity	<ul style="list-style-type: none"> <li>● ≤ -107 dBm (typ.) @ 850 MHz</li> <li>● ≤ -107 dBm (typ.) @ 900 MHz</li> <li>● ≤ -108 dBm (typ.) @ 1800 MHz</li> <li>● ≤ -107 dBm (typ.) @ 1900 MHz</li> </ul>	
GPRS connectivity	GPRS multi-slot class 12	
Audio	Analog interface. Integrated maximum 0.8W high power class AB	

	speaker amplifier.
SIM interface	Support SIM card: 1.8V, 3.0V
SMS	Text and PDU mode
Bluetooth feature	Description
Output power	Maximum 4dBm ± 3dBm.
version	Bluetooth specification 3.0

**1.2 Block diagram**



**Figure 1: Module block diagram**

## 2. Pin definition

### 2.1 Pin assignment

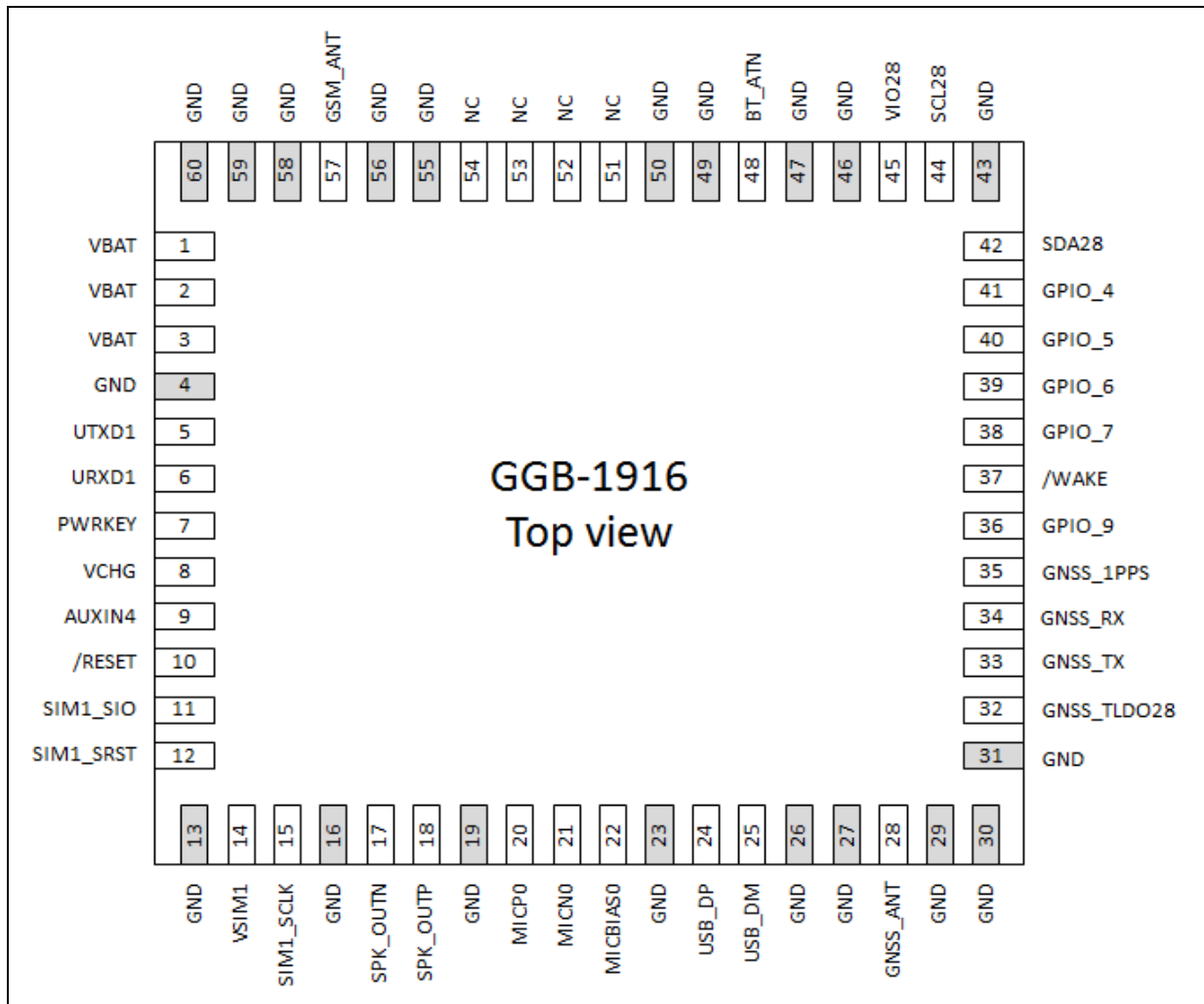


Figure 2: Pin assignment

### 2.2 Pin description

Table 2: Pin description

Pin #	Name	I/O	Description	Remarks
1	VBAT	I	Power supply input	
2	VBAT	I	Power supply input	
3	VBAT	I	Power supply input	
4	GND		Ground	
5	UTXD1	O	UART transmitted data. Power domain: VIO28.	IO Type 2
6	URXD1	I	UART received data. Power domain: VIO28.	IO Type 3
7	PWRKEY	I	Power on/off key. This pin is internally pulled up to VBAT.	



8	VCHG		Reserved pin. Leave unconnected.	
9	AUXIN4	I	ADC channel	
10	/RESET	O	System reset. Power domain: 1.8V.	
11	SIM1_SIO	I/O	SIM data	
12	SIM1_SRST	O	SIM reset	
13	GND		Ground	
14	VSIM1	O	SIM power supply output. Automatically supply the right voltage (1.8V or 3V) to SIM card.	
15	SIM1_SCLK	O	SIM clock	
16	GND		Ground	
17	SPK_OUTN	O	Negative voice output. Class AB, 0.8W @ 3.7V, 8ohm.	
18	SPK_OUTP	O	Positive voice output. Class AB, 0.8W @ 3.7V, 8ohm.	
19	GND		Ground	
20	MICP0	I	Microphone positive input	
21	MICN0	I	Microphone negative input	
22	MICBIAS0	O	Microphone bias output	
23	GND		Ground	
24	USB_DP		Reserved pin. Leave unconnected.	
25	USB_DM		Reserved pin. Leave unconnected.	
26	GND		Ground	
27	GND		Ground	
28	GNSS_ANT	I	GNSS antenna pad (50 ohm impedance)	
29	GND		Ground	
30	GND		Ground	
31	GND		Ground	
32	GNSS_TLDO28	O	2.8V power output for GNSS active antenna. Do not use for the other purposes, otherwise GNSS may fail to function properly.	
33	GNSS_TX	O	GNSS transmitted data. Internally connected to the baseband. For normal operation, please leave unconnected. Power domain: 2.8V.	IO Type 2
34	GNSS_RX	I	GNSS received data. Internally connected to the baseband. For normal operation, please leave unconnected. Power domain: 2.8V.	IO Type 3
35	GNSS_1PPS	O	GNSS 1PPS output, default 100ms pulse/sec when 3D position fix is available. Power domain: 2.8V.	
36	GPIO_9	I/O	General purpose input/output. Power domain: VIO28.	IO Type 2

37	/WAKE	I	Falling edge triggered input with an internal pull-up resistor. Pull this pin from high level to low level to wake up the module from sleep mode. Power domain: VIO28.	IO Type 2
38	GPIO_7	I/O	General purpose input/output. Power domain: VIO28.	IO Type 2
39	GPIO_6	I/O	General purpose input/output. Power domain: VIO28.	IO Type 2
40	GPIO_5	I/O	General purpose input/output. Power domain: VIO28.	IO Type 2
41	GPIO_4	I/O	General purpose input/output. Power domain: VIO28.	IO Type 2
42	SDA28	I/O	I <sup>2</sup> C data. Power domain: VIO28.	IO Type 2
43	GND		Ground	
44	SCL28	O	I <sup>2</sup> C clock. Power domain: VIO28.	IO Type 2
45	VIO28	O	2.8V power output.	
46	GND		Ground	
47	GND		Ground	
48	BT_ANT	I/O	Bluetooth antenna pad (50 ohm impedance).	
49	GND		Ground	
50	GND		Ground	
51	NC		Not connected	
52	NC		Not connected	
53	NC		Not connected	
54	NC		Not connected	
55	GND		Ground	
56	GND		Ground	
57	GSM_ANT	I/O	GSM antenna pad (50 ohm impedance).	
58	GND		Ground	
59	GND		Ground	
60	GND		Ground	

### 3. Electrical specifications

#### 3.1 Absolute maximum rating

**Table 3: Absolute maximum rating**

Parameter	Symbol	Minimum	Maximum	Unit
Power supply input	V <sub>BAT</sub>	-0.3	4.3	V
Digital input voltage for IO Type 2	V <sub>IN2</sub>	-0.3	3.08	V
Digital input voltage for IO Type 3	V <sub>IN3</sub>	-0.3	3.63	V
Storage temperature	T <sub>Astg</sub>	-40	85	°C

#### 3.2 Electrical characteristics

**Table 4: Electrical characteristics**

Parameter	Symbol	Conditions	Min.	Typ.	Max.	Unit
Power supply input	V <sub>BAT</sub>		3.4	3.8	4.2	V
TCXO LDO output	T <sub>LDO28</sub>		2.66	2.8	2.89	V
TCXO LDO output current	I <sub>T<sub>LDO28</sub></sub>				20	mA
2.8V power output	V <sub>IO28</sub>		2.66	2.8	2.94	V
2.8V output current	I <sub>V<sub>IO28</sub></sub>			50	80	mA
Module peak of current consumption through all VBAT pins	I <sub>PEAK</sub>				2	A
Shutdown current	I <sub>OFF</sub>	Power off		152		μA
High level input voltage	V <sub>IH</sub>	IO Type 2	2.1		3.08	V
		IO Type 3	2.1		3.6	
Low level input voltage	V <sub>IL</sub>		-0.3		0.7	V
High level output voltage	V <sub>OH</sub>		2.38	2.8	2.94	V
Low level output voltage	V <sub>OL</sub>		0		0.42	V

**Table 5: Current consumption of GGB-1916-A**

GSM	Bluetooth	GNSS	Can CPU sleep <sup>*1</sup>	Typical current
Normal mode (AT+CFUN=1)	Off	Off	No	9.2 mA <sup>*2</sup>
Radio off (AT+CFUN=0)	Off	Off	Yes	0.76 mA
Radio off (AT+CFUN=0)	Off	Off	No	8.9 mA
GSM sleep, DRX=2 <sup>*3</sup>	Off	Off	Yes	1.41 mA
GSM sleep, DRX=5 <sup>*3</sup>	Off	Off	Yes	1.05 mA
GSM sleep, DRX=9 <sup>*3</sup>	Off	Off	Yes	0.96 mA
GSM talk mode @ 850MHz <sup>*4</sup>	Off	Off	Yes/No	189 mA
GSM talk mode @ 900MHz <sup>*4</sup>	Off	Off	Yes/No	191 mA
GSM talk mode @ 1800MHz <sup>*5</sup>	Off	Off	Yes/No	123 mA
GSM talk mode @ 1900MHz <sup>*5</sup>	Off	Off	Yes/No	115 mA
GPRS 4Tx + 1Rx @ 850MHz <sup>*6</sup>	Off	Off	Yes/No	400 mA
GPRS 4Tx + 1Rx @ 900MHz <sup>*6</sup>	Off	Off	Yes/No	402 mA
GPRS 4Tx + 1Rx @ 1800MHz <sup>*7</sup>	Off	Off	Yes/No	258 mA
GPRS 4Tx + 1Rx @ 1900MHz <sup>*8</sup>	Off	Off	Yes/No	231 mA
Radio off (AT+CFUN=0)	Off	Acquisition	Yes	23.9 mA
Radio off (AT+CFUN=0)	Off	Acquisition	No	31.9 mA
Radio off (AT+CFUN=0)	Off	Tracking	Yes	22.4 mA
Radio off (AT+CFUN=0)	Off	Tracking	No	29.9 mA
Radio off (AT+CFUN=0)	On, connectable	Off	Yes	0.78 mA
Radio off (AT+CFUN=0)	On, connectable	Off	No	8.9 mA
Radio off (AT+CFUN=0)	On, connected, idle	Off	Yes	0.98 mA
Radio off (AT+CFUN=0)	On, connected, idle	Off	No	9 mA

<Note>

1. Sleep mode can be enabled by AT command "AT+LSSLEEP=1". When CPU is sleep, it cannot respond to any AT commands via URXD1 pin.
2. Tested with DRX = 5. The module is powered on in the mode of normal GSM (AT+CFUN=1), Bluetooth off, GNSS off and CPU sleep disabled.
3. @ 850MHz, 900MHz, 1800MHz, 1900MHz.
4. PCL = 5, Maximum TX power (32.3 dBm typ.)
5. PCL = 0, Maximum TX power (29 dBm typ.)
6. Maximum TX power (28.9 dBm typ.)
7. Maximum TX power (26.5 dBm typ.)
8. Maximum TX power (27.9 dBm typ.)

**Table 6: Current consumption of GGB-1916-B**

GSM	Bluetooth	GNSS	Can CPU sleep <sup>*1</sup>	Typical current
Normal mode (AT+CFUN=1)	Off	Off	No	12.4 mA <sup>*2</sup>
Radio off (AT+CFUN=0)	Off	Off	Yes	0.57 mA
Radio off (AT+CFUN=0)	Off	Off	No	12 mA
GSM sleep, DRX=2 <sup>*3</sup>	Off	Off	Yes	1.4 mA
GSM sleep, DRX=5 <sup>*3</sup>	Off	Off	Yes	0.99 mA
GSM sleep, DRX=9 <sup>*3</sup>	Off	Off	Yes	0.86 mA
GSM talk mode @ 850MHz <sup>*4</sup>	Off	Off	Yes/No	210 mA
GSM talk mode @ 900MHz <sup>*4</sup>	Off	Off	Yes/No	210 mA
GSM talk mode @ 1800MHz <sup>*5</sup>	Off	Off	Yes/No	144 mA
GSM talk mode @ 1900MHz <sup>*5</sup>	Off	Off	Yes/No	133 mA
GPRS 4Tx + 1Rx @ 850MHz <sup>*6</sup>	Off	Off	Yes/No	416 mA
GPRS 4Tx + 1Rx @ 900MHz <sup>*6</sup>	Off	Off	Yes/No	419 mA
GPRS 4Tx + 1Rx @ 1800MHz <sup>*7</sup>	Off	Off	Yes/No	265 mA
GPRS 4Tx + 1Rx @ 1900MHz <sup>*8</sup>	Off	Off	Yes/No	237 mA
Radio off (AT+CFUN=0)	Off	Acquisition	Yes	23.7mA
Radio off (AT+CFUN=0)	Off	Acquisition	No	34.9 mA
Radio off (AT+CFUN=0)	Off	Tracking	Yes	22 mA
Radio off (AT+CFUN=0)	Off	Tracking	No	32.7 mA
Radio off (AT+CFUN=0)	On, connectable	Off	Yes	0.6 mA
Radio off (AT+CFUN=0)	On, connectable	Off	No	12.1 mA
Radio off (AT+CFUN=0)	On, connected, idle	Off	Yes	0.84 mA
Radio off (AT+CFUN=0)	On, connected, idle	Off	No	12.2 mA

<Note>

1. Sleep mode can be enabled by AT command "AT+LSSLEEP=1". When CPU is sleep, it cannot respond to any AT commands via URXD1 pin.
2. Tested with DRX = 5. The module is powered on in the mode of normal GSM (AT+CFUN=1), Bluetooth off, GNSS off and CPU sleep disabled.
3. @ 850MHz, 900MHz, 1800MHz, 1900MHz.
4. PCL = 5, Maximum TX power (32.3 dBm typ.)
5. PCL = 0, Maximum TX power (29 dBm typ.)
6. Maximum TX power (28.9 dBm typ.)
7. Maximum TX power (26.5 dBm typ.)
8. Maximum TX power (27.9 dBm typ.)

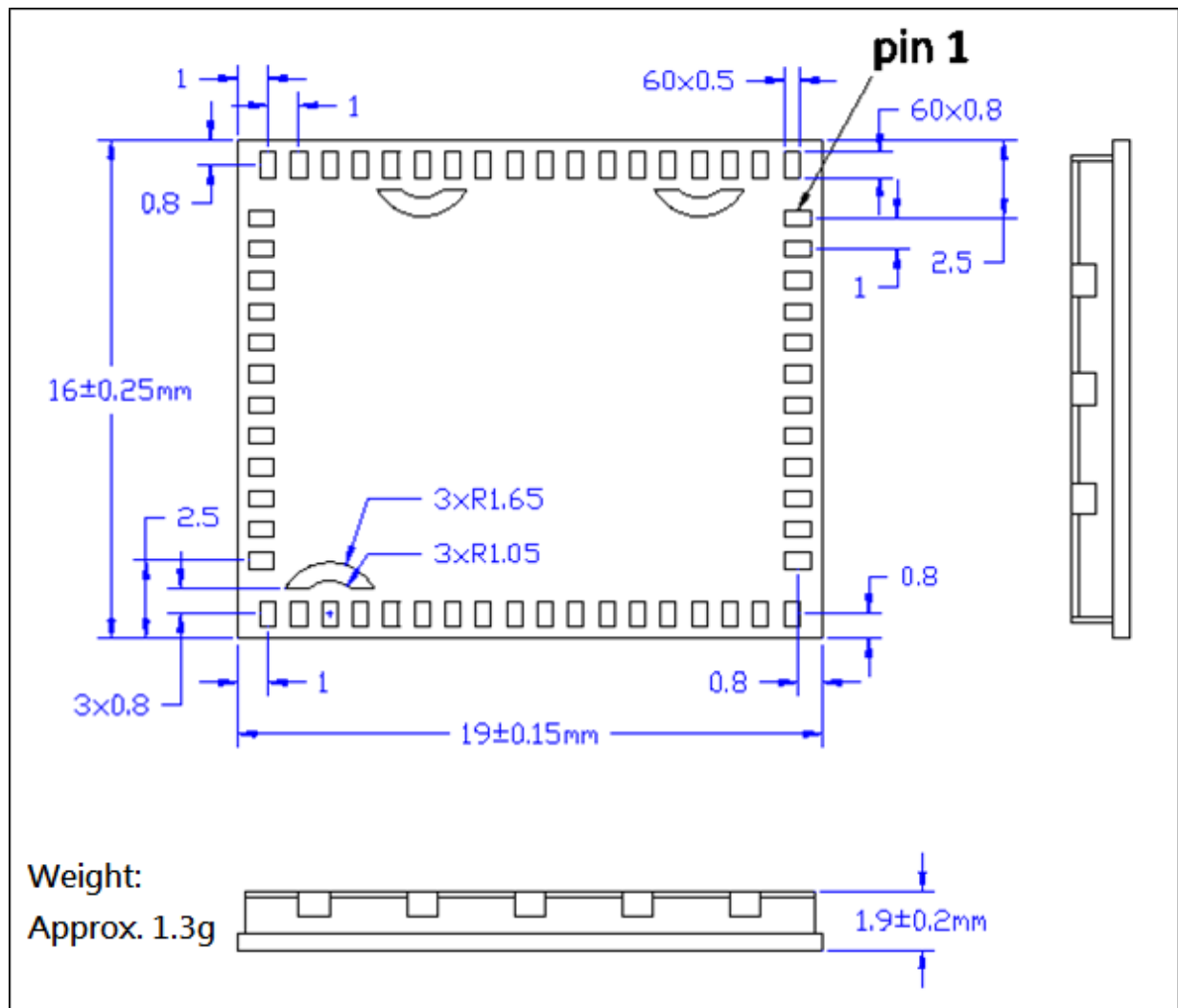
### 3.3 Temperature characteristics

**Table 7: Temperature characteristics**

Parameter	Symbol	Minimum	Typical	Maximum	Unit
Normal operating temperature	T <sub>opr</sub>	-20	25	85	°C
Storage temperature	T <sub>stg</sub>	-40	25	85	°C

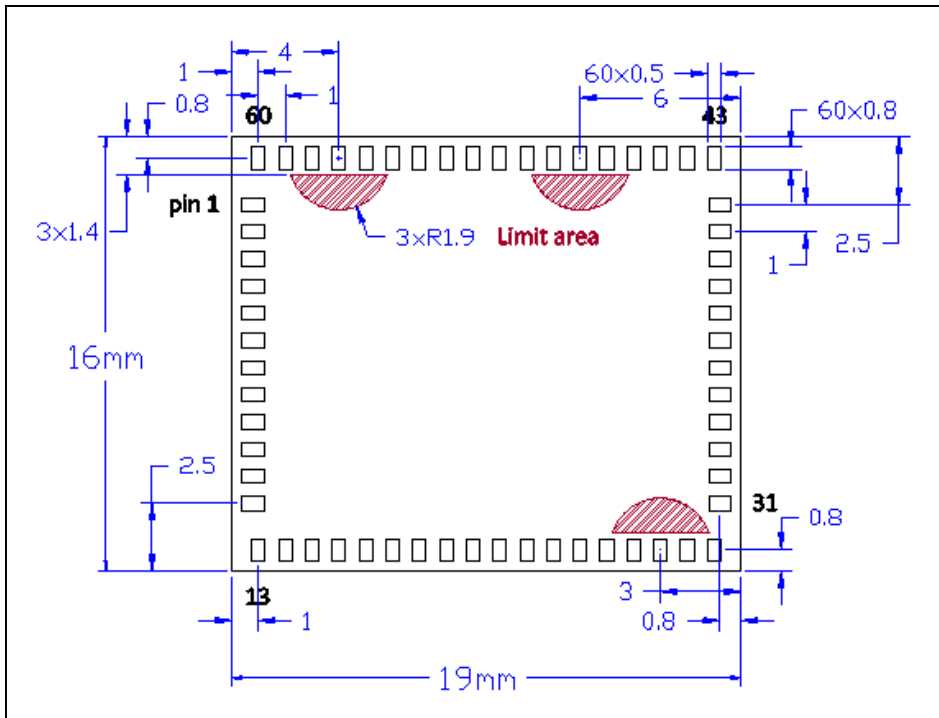
## 4. Mechanical specification

### 4.1 Outline dimensions

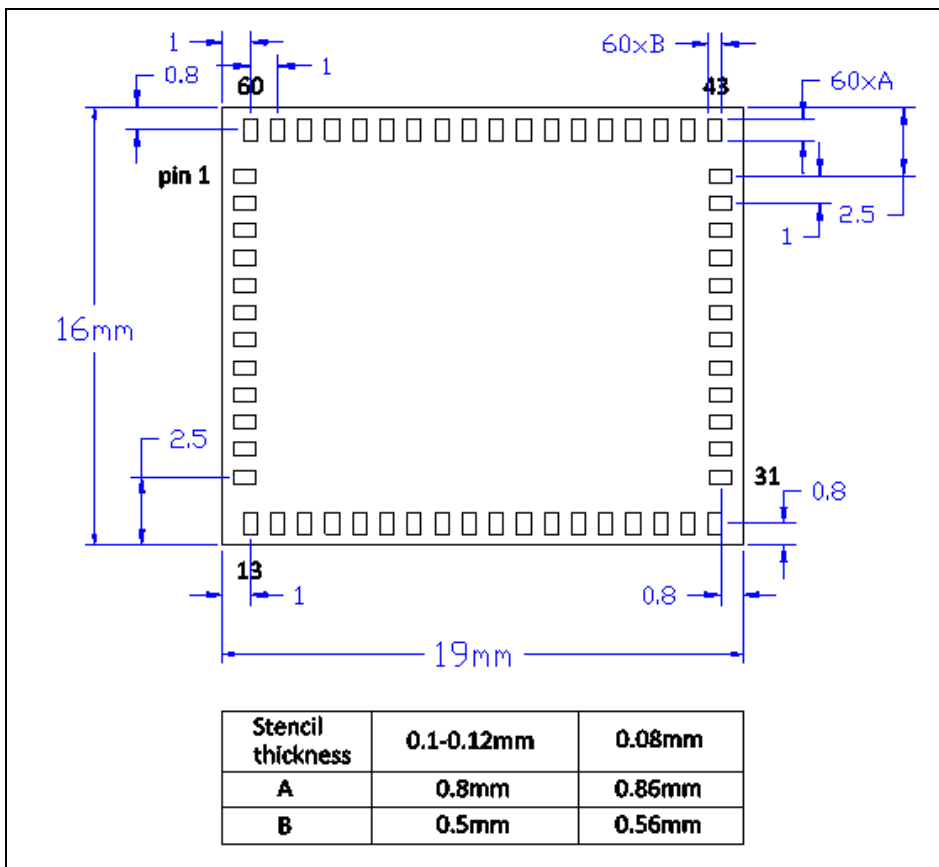


**Figure 3: Outline dimensions**

**4.2 Recommended layout pattern**



**Figure 4: Recommended land pattern dimensions**



**Figure 5: Recommended stencil design**

## 5. Product handling

### 5.1 ESD precaution

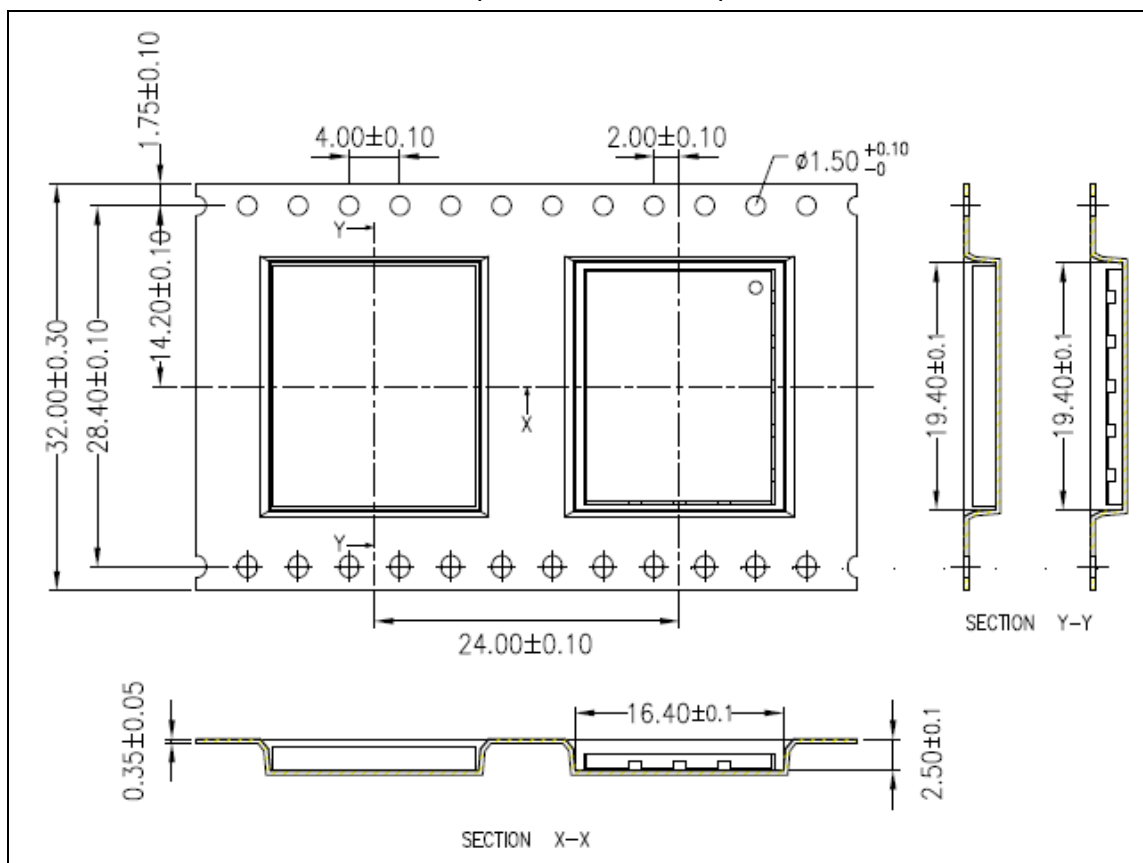
GGB-1916 modules are electrostatic sensitive devices. Handling the modules without proper ESD protection may result in severe damage to them. ESD protection must be implemented throughout the processing, handling and even when the modules are being returned for repair.

### 5.2 Packaging

The modules are sealed in a moisture barrier ESD bag with the appropriate units of desiccant and a humidity indicator card. It should not be opened until the modules are ready to be soldered onto the application.

#### 5.2.1 Tape and reel packaging

The modules are deliverable in quantities of 1,000 pieces on a reel of 330mm in diameter.



**Figure 6: tape dimensions (mm)**



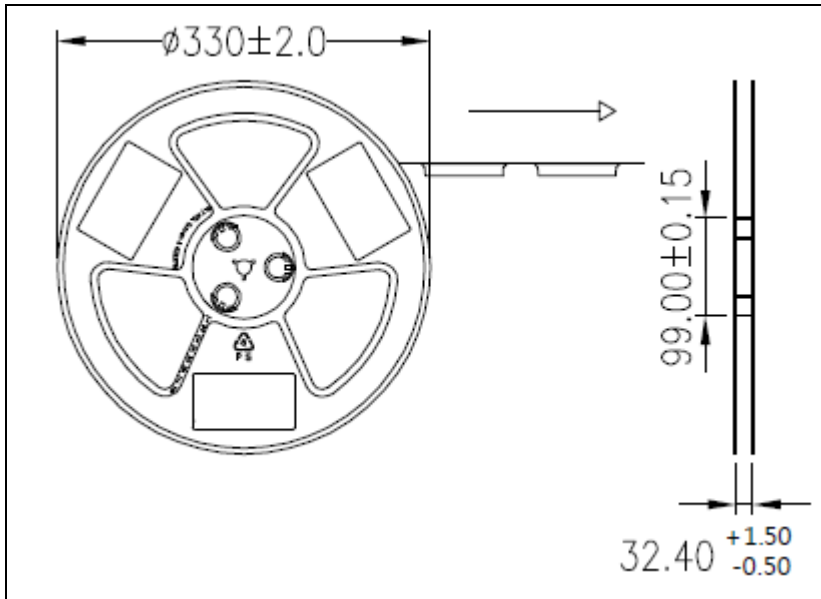


Figure 7: reel dimensions (mm)

**5.2.2 Box packaging**

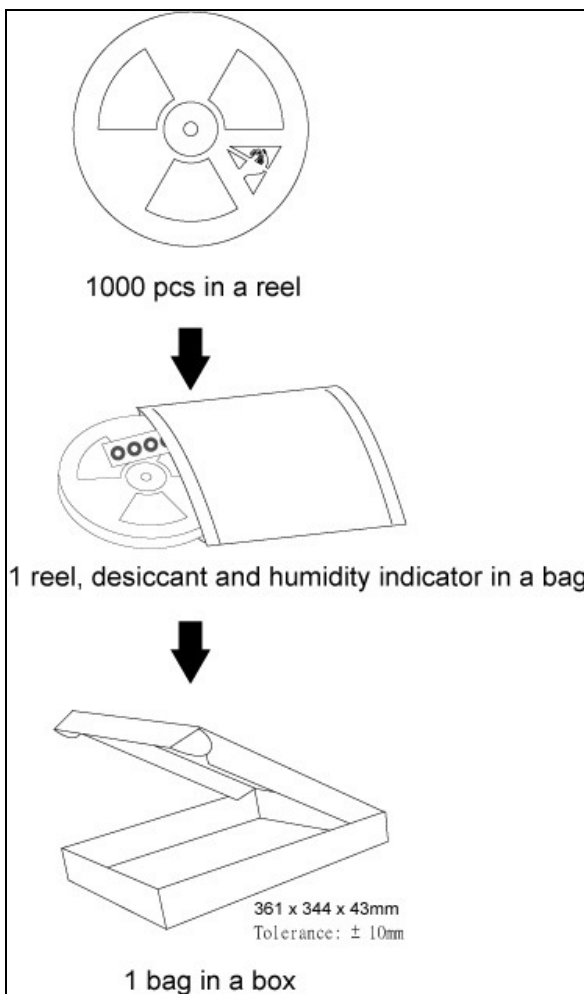


Figure 8: Box packaging

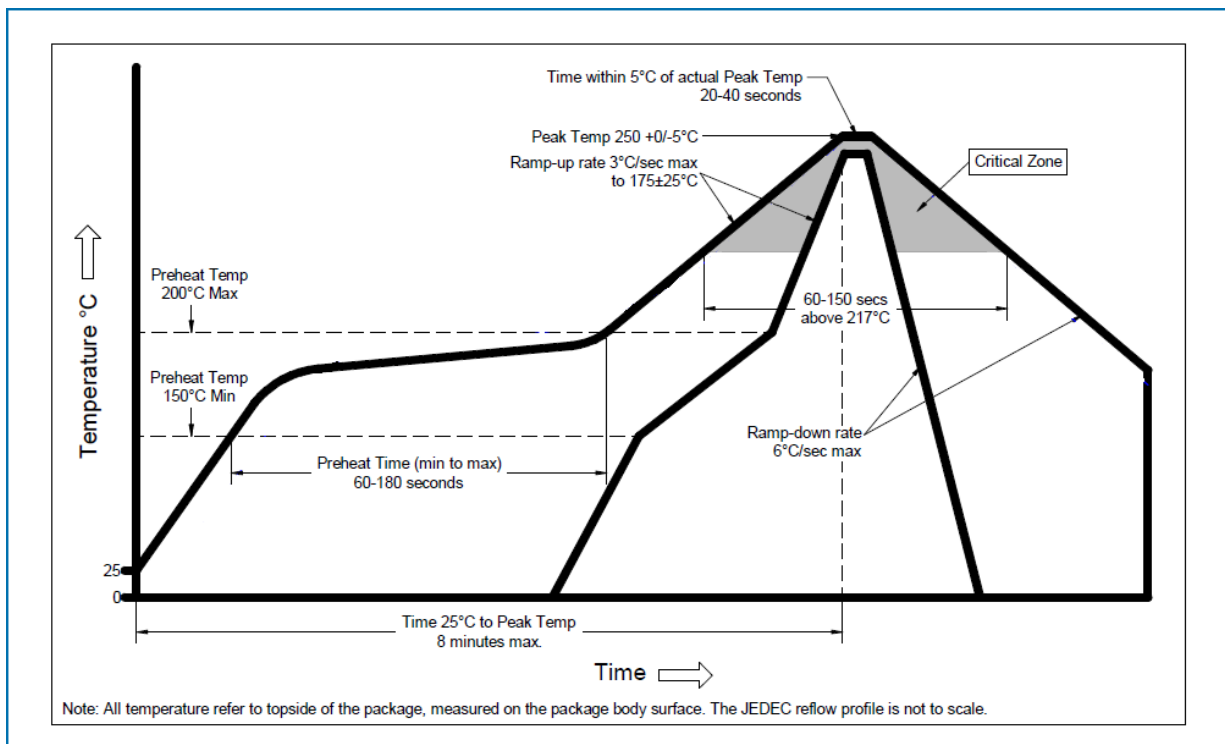
### 5.3 Moisture sensitivity level

The moisture sensitivity level of the module is 3. After the sealed bag is opened, modules should be mounted within 168 hours at factory conditions of  $\leq 30^{\circ}\text{C}$  and 60% RH or stored at  $\leq 20\%$  RH.

The modules require baking before mounting if above conditions are not met. If baking is required, the modules may be baked for:

- a. 192 hours at  $40^{\circ}\text{C} + 5^{\circ}\text{C} / -0^{\circ}\text{C}$  and  $< 5\%$  RH
- b. 24 hours at  $125^{\circ}\text{C} + 5^{\circ}\text{C} / -0^{\circ}\text{C}$

### 5.4 Reflow soldering



**Figure 9: Recommended reflow profile**

## 6. Product marking and ordering information

### 6.1. Product marking

The marking of GGB-1916 is engraved on the metal shielding that has product information, such as LOCOSYS logo, product name, serial number, IMEI number, MAC address and manufacturing date.

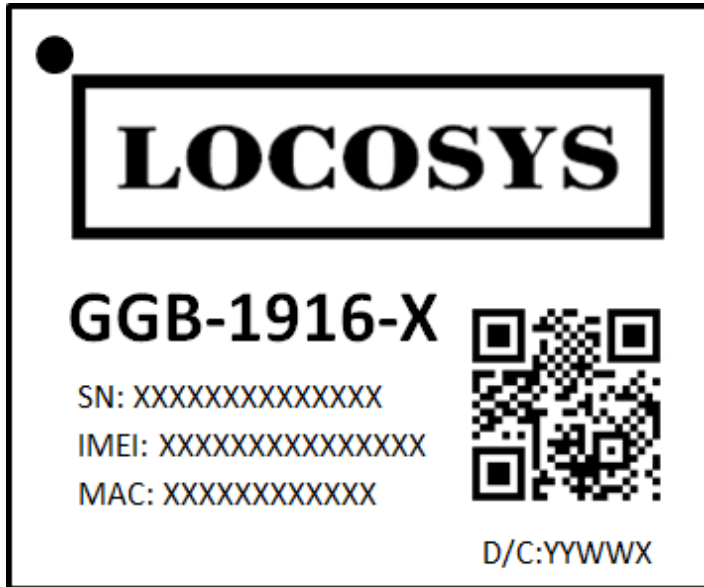


Figure 10: Label of GGB-1916 module

### 6.2. Ordering information

Table 8: Ordering information

Product name	Description	Remark
GGB-1916-A	Built-in high efficient DC/DC converter to save power.	
GGB-1916-B	Without high efficient DC/DC converter.	Recommended